

# Megado

## Instruction manual



### Contents

Introduction .....	1
Tips for assembling the loom .....	2
Assembly of the loom.....	3
Assembling the mechanical dobby system.....	22
Installing the electronic interface .....	29
Tips and tricks for using the loom.....	29
Maintenance .....	34
Trouble shooting .....	34
Contact .....	37



## Introduction

### Megado's countermarch action produces a perfect shed automatically

The Megado is not literally a countermarch loom although it has all the advantages of one. In countermarch looms, the shafts move both up and down so that tension on both raised and lowered warp threads is equal. With the Megado, as the treadle is depressed, the rising shafts move, and as they rise, the back part of the loom also rises. This action automatically creates a shed of raised and lowered threads that is progressively greater toward the back and therefore completely even at the front in addition to equalizing tension on all warp threads.

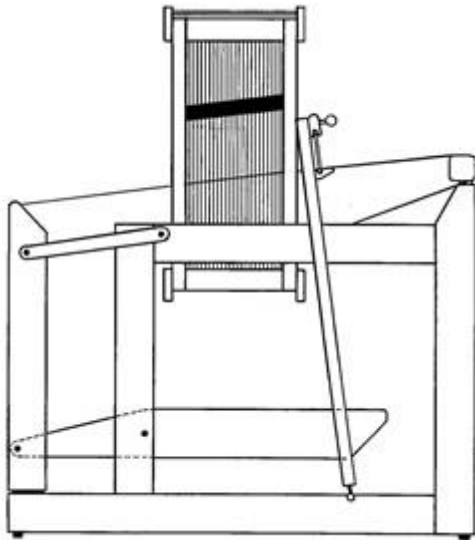

*Megado at rest*

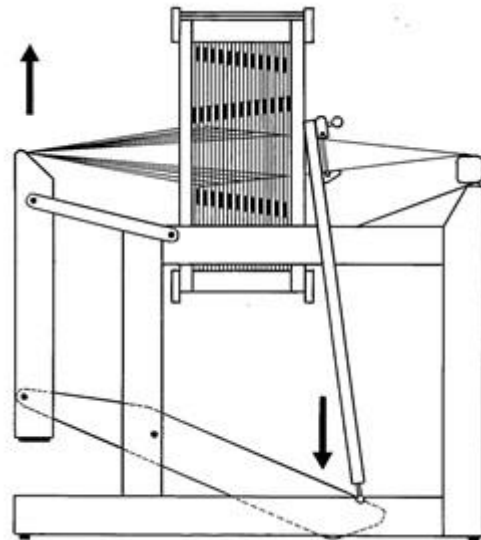

*Progressive shed achieved during treadling*

### Megado treadling is very light

When a shed is formed on most looms, the activated warp threads move through a greater distance than they do at rest. This means that the activated warp threads are under greater tension, and they become stretched. If the warp is of an inelastic material and held at high tension, the force required to treadle can be considerable.

With the Louët Spring and Delta countermarch looms, this problem is overcome to some degree: The breast beam moves during treadling to decrease the distance between front and back beams, therefore decreasing the distance through which the activated threads move.

With the Megado and Octado looms, the problem is completely overcome: Not only does the back part of the loom move up, but the back beam also moves a little towards the breast beam during treadling. This causes activated warp tension to decrease from even its resting tension—actually helping you make the shed!

When you have a wide loom (110 or 130 cm) or add a second warp beam or sectional warp kit, there is more weight on the back part of the loom, which will make it harder to treadle. You can add springs to the loom that will help to lift the back part when you push the pedal to make a shed. These springs are standard included with the 110 and 130 cm looms and with all second warp beams and sectional warp kits.

## **Accessories**

Besides the choice of a mechanical or an electronic dobbie head, you can obtain a full range of accessories:

- Adjustable bench (59-72 cm)
- Tilting set for bench
- Second warp beam with back beam
- Sectional warp beam Flying Dutchman shuttle
- Fly shuttle device
- Treadle height adjusting blocks
- Program bars in sets of 10
- Beater suspension kit

## **Tips for assembling the loom**

### **Ask a friend**

During the assembly of the loom, there will be some moments that you will need assistance. The middle section or the assembled loom is difficult to move by oneself. For these tasks, we advise you to ask a friend or a family member for help.

### **Barrel nuts**

For the assembly of the looms, we use many barrel nuts and bolts to connect two parts. The cylinder shaped nuts have a slot on one of the flat sides. Always insert the barrel nut into the wooden part, so that the slot in the barrel nut is visible. The slot shows the direction of the threaded hole in the nut. With a flat screwdriver you can turn the barrel nut so that it is positioned properly to catch the bolt. If you have a problem inserting the bolt into the barrel nut, try turning the barrel nut 180 degrees. This usually helps.

### **Carriage bolts**

In other locations, we use carriage bolt to assemble wooden parts. These bolts have a square enlargement (neck) under the bolt head. When you tighten the nut on the bolt, this square neck locks into the wood to prevent the bolt from turning. To prevent the bolt from turning before the square neck is locked into the wood, use a hammer to tap the head and then tighten the nut.

In some instances, you will notice, that the bolt is just a little too short for assembly with the washer and nut. We advise you to put the nut on the bolt without the washer, then tighten the nut sufficiently, so that the square neck pulls into the wood. At this stage, unscrew the nut, install the washer and then replace and secure the nut again, tightly. Alternatively, you can tap against the bolt head with a hammer, until the thread of the bolt protrudes far enough to tighten the nut.

### **Washers and spacers**

For the proper operation of the loom, it is very important that you follow the proper assembly sequence of the bolts, washers and spacers. Please carefully follow the instructions. To help you, we have assembled all the washers and spacers in the hardware bags in the right sequence.

### **Wood screws**

Where wood screws are used, we have pre-drilled holes in the wood. The screws will cut their own thread into these holes. Please note however, that the screws are very sharp, and will cut into the full wood outside the pre-drilled holes, if you miss the pre-drilled hole during assembly. However if this happens, you will notice that after a couple of turns, it becomes too hard to turn the screw. There is even a chance that the screw will twist off. Moreover, the parts will be assembled in the wrong location.

If you have to assemble and disassemble the loom several times, make sure that the wood screw turns in the same thread again which was cut the first time. To find this screw thread, turn the screw anti clock wise, until you "feel" the screw "drop" into the threaded part in the wood. If you do not follow this instruction, the hole in the wood will become too large to hold the screw after several assembling and disassembling actions.

## Markings

Many parts of the loom have been marked with letters of the alphabet at places where they have to be connected to another part, marked with the same letter. The first time a part is named in this instruction; these letters are mentioned, to indicate which part is meant.

## Tools

All parts used for the loom are metric. To facilitate the assembly, we have included two wrenches (10 mm for M6, 13 mm for M8) and a pz2 cross head screwdriver (not a Phillips head!). Together with hardware bags 1, 2 and 5, these tools are located in box B. All bolts, washers, bushings and nuts that are packed in the hardware bags are assembled in the correct sequence. In addition to the middle part in box A, the first parts needed for the assembly are packed in box B.

## Assembly of the loom

### 1. Assembling the side rails to the middle section



Open hardware Bag 1:

- 8 bolts M8 x 130 mm, with large washer and barrel nut
- 2 bolts M8 x 70 mm, with large washer and barrel nut
- 4 bolts M6 x 70 mm, with washer and barrel nut
- 4 carriage bolts M8 x 65 mm, each with large washer, two small washers, and a cap nut
- 4 carriage bolts M8 x 50 mm, each with a large ring and cap nut
- 4 rubber buffers

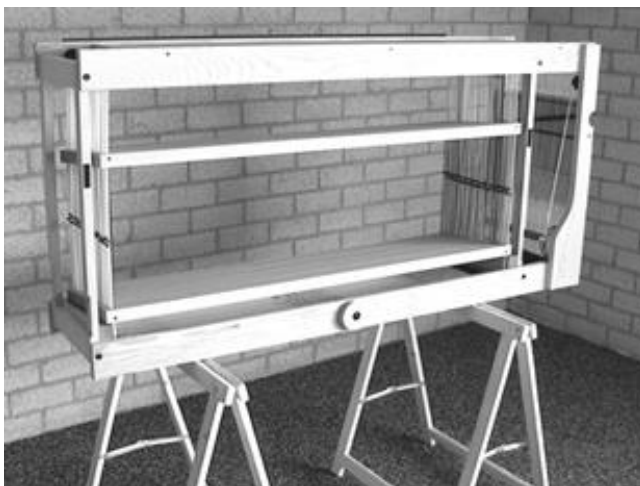

Use two sawhorses, a table, or the empty Box A to support the middle section of the loom raised at about 24"-32" above the floor.

Find the two upper side rails marked JND and IMC and also the two hinged arms, which you can recognize by the six metal hooks.



Connect them using 2 of the 4 carriage bolts M8 x 65 mm, with the large washer, two small washers, and cap nut. The hooks should be positioned like the picture shows and see page 2 for the carriage bolts tips.

The 3 washers should be placed in between the two wooden parts; the 2 small washers against the ball bearing. Tighten the connection with the cap nut against the ball bearing at the other side (no washer in between).

These hooks are used for the spring system that will help to lift the back part when you push the pedal to make a shed. These springs are standard included with the 110 and 130 cm looms and with all second warp beams and sectional warp kits.



Assemble side rails JND and IMC each with two M8 x 50 mm carriage bolts, large washer, and cap nut to the middle section. The front connections of the side rails to the middle section are marked M-M and N-N.



Put the two remaining M8 x 65 mm carriage bolts into the remaining hole of each hinged arm and add the washers and cap nuts. Place the hinged arms with the carriage bolts on the side rails, as shown in the picture.

## 2. Assembling the side parts of the frame



Take the middle posts AC and BD and slide these onto the wooden pegs of the side rails (connections C-C and D-D). For both connections use an M8 x 130 mm bolt with large washer and barrel nut.



Take the lower side rails AE and BF and the front posts LJHF and KIGE and attach the rubber buffers by screwing them into the threaded holes.



Now assemble both bottom side rails below the already assembled vertical posts by sliding them over the wooden pegs. Tighten these joints (A-A and B-B) with an M8 x 130 mm bolt, large washer, and barrel nut.



Slide the front posts over the wooden pegs of the upper and lower side rails and make the connections I-I, J-J, F-F, and E-E with the four remaining M8 x 130 mm bolts, large washers, and barrel nuts.

### 3. Mounting the foot rail and cross member



Take the foot rail GH out of Box D and slide it with its wooden pegs into the holes from one of the front posts. Watch out for the proper position of the foot rail; the holes for the barrel nuts have to face the loom. Let the wooden pegs of the other side of the foot rail rest on the lower side rail.



Apply pressure to the side where the foot rail pegs rest so that the side moves out, allowing the pegs of the foot rail to fall into place.

Connect and tighten at both sides with M8 x 70 mm bolts, large washer, and barrel nut.

Since the loom can now stand on its own, remove the trestles or whatever you have used to support the middle section.





Next, assemble the wide cross member between the two vertical posts at the rear of the middle section:

Take four M6 x 70 mm bolts from the hardware bag and place them complete with their washers into the four holes of the middle posts

Take the wide cross member out of Box C. You can recognize this cross member by the four barrel nut holes at either end.



Slide the cross member on one side onto the M6 x 70 mm bolts that protrude on the inside of the middle post.

Then place the cross member between both middle posts and push the bolts into the holes to find the right position.

Insert the barrel nuts and tighten the bolts.

#### 4. Assembling the treadle arms



Open hardware bag 2:

- 4 carriage bolts 8 x 75 mm with large washer, small washer, spacer, and cap nut.
- 2 bolts M8 x 70 mm with large washer and barrel nut.
- 1 threaded hook M6 x 60 mm with barrel nut.
- 4 screws 5 x 40 mm with counter sunk cross head.
- 8 screws 5 x 50 mm



Take the treadle arms out of Box B and assemble each with an M8 x 75 mm carriage bolt onto a middle post of the loom, using the holes where ball bearings are present. Make sure that you assemble the section between the treadle arm and ball bearing in the correct sequence: Consecutively slide the large washer, the small washer, and the bushing onto the bolt after you put it through the hole in the treadle arm.

Tighten the bolt with a cap nut. You don't need a washer on the outside between the ball bearing and the cap nut.



Take the back post P out of Box B. You can recognize the back posts by their markings O and P and by the two holes with ball bearings.

Connect back post P to the right treadle arm with the M8 x 75 mm carriage bolt. Make the connection in the same manner as the treadle arm to the middle post.



Turn the hinged arm, which rests on the side rail, backwards and connect it into the other ball bearing hole in the back post. Remember to put the three washers onto the bolt, in between the hinged arm and the ball bearing.

## 5. Assembling the warp beam and the back beam

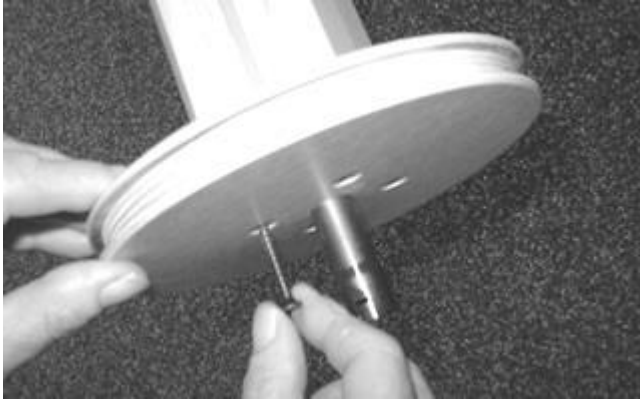

Take the brake disk out of Box B and the warp beam out of Box D. Both are marked Q.

Slide the brake disk onto the longer shaft of the warp beam with the side marked Q facing the beam.

Use the four 5 x 40 mm screws to attach the disk to the warp beam.

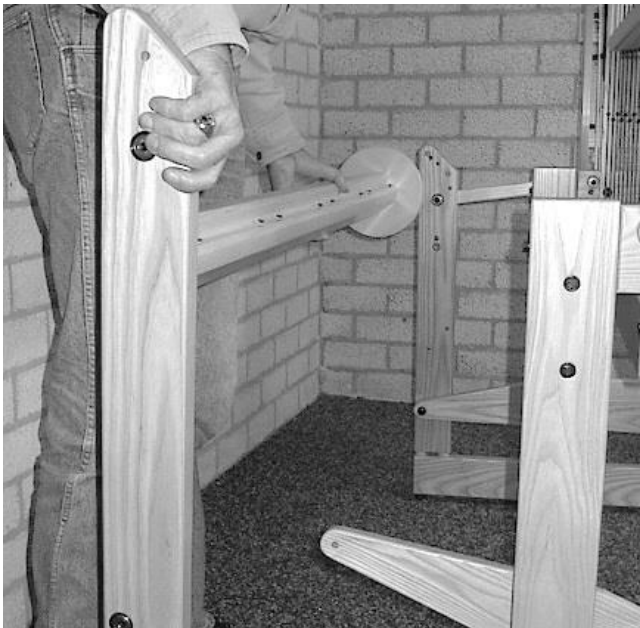

Slide the left back post marked O onto the shorter shaft of the warp beam and install this onto the loom. The larger shaft, protruding from the brake disk, has to be inserted into the hole in the right back post.

Let the other back post, the left one, rest on the lower side rail.



Connect the left back post with the treadle arm in the same manner as you did on the other side.



Take the back beam, marked P O out of box D. First insert the wooden pegs of the back beam on side P into the holes in the right back post. Make sure that the holes for the barrel nuts point diagonally downwards.



Put the wooden pegs on side O of the back beam into the holes of the left back post (Connection O-O). You will have to carefully bend the back post towards the outside, making sure that the warp beam does not drop out of the loom (you might need some help with this).

Tighten the back beam with two M8 x 70 mm bolts, large washer, and barrel nut. Connect the hinged arm to the left back post in the same manner as you did on the right side.

## 6. Assembling the treadle

Now you will attach the treadle rail and the connection rail (from Box C) to the treadle arms. There are four holes in each treadle arm for the attaching of the connection rail. You will only use two on each side: The two holes farthest from the front of the loom are used for the 16-shaft loom. The holes that are closer to the front are used for the 32-shaft loom.

To assemble the treadle rail, you will find that each treadle arm has three sets of holes above each other. The holes you use depends on the height of the treadle rail that is comfortable for you. The middle set of holes is usually appropriate for weavers who are between 5'-7" and 5'-11" (1.70 –1.80 m). The comfortable height of the treadle rail also depends on the height of the bench being used. We can supply additional blocks and rails to make the loom comfortable for very short weavers.



Take the connection rail out of Box C (the connection rail has a hole for the barrel nut in the middle that is used for connecting the cable) and take four of the remaining screws.

Hold the rail between the treadle arms. Be sure that the holes for the connection to the cable are at the back side and on top. Place a screw into the top hole of the treadle arm and while doing so, adjust the connection rail to find the pilot hole. The top of the connection rail should be 1/6" (4mm) under the top of the treadle arm.

Then turn the screw so far by hand that only the tip enters the pilot hole. Repeat this with the other screw into the lower hole. As long as you keep the rail horizontal, it will remain in place on the tips of the screws.

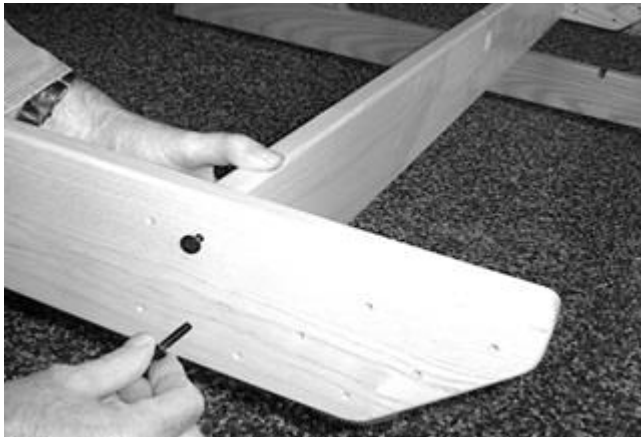

Move over to the other side of the loom, keeping the rail in a horizontal position. Place two screws into the holes in the other treadle arm and adjust the connecting rail to find the pilot holes as before. The rail now hangs on four screw points. Now take the screwdriver and turn all four screws partly in. The heads of the screws have to stick out a little because some space is required to install the treadle bar.

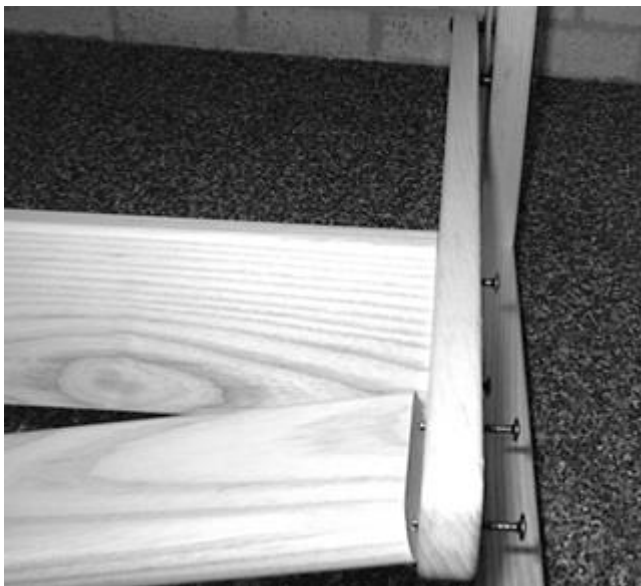

Take the four remaining screws and the treadle bar, which you can recognize by the two rounded sides, out of Box C. Lay the treadle bar between the treadle arms on the floor.

Lift the treadle bar up on one side and hold it up against the treadle arm. Insert two screws through the holes of the treadle arm and turn the screw tips into the pilot holes of the treadle bar until it remains in position.



Carefully lift the treadle bar on the opposite side and slide it into its place between the arms. Place the screws into the holes of the treadle arm and find the pilot holes by adjusting the treadle bar.

Now tighten all screws of the treadle bar with the screwdriver and then tighten the screws that hold the connecting rail.

## 7. The connection of the treadle and the dobbie knife and adjusting the knife at the proper height

Each shaft is connected to a dobbie hook by a cord. Dobby hooks are the pieces of wood with two protruding screw heads. When the dobbie hook is not activated, one of its screw heads locks the shaft in its lowermost position. When a dobbie hook is pushed by the dobbie head, the hook unlocks and the other screw head will be caught by the knife as you push down the treadle for the shed. When the dobbie hook is pulled down by the knife, it lifts the shaft connected to that dobbie hook. The knife is the steel bar on the right side of the loom which will move up and down with the treadle.

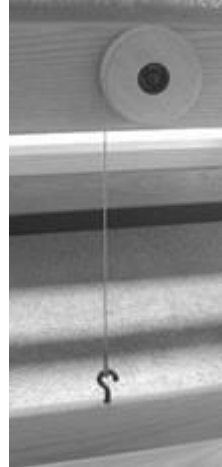

The knife is attached to a rotatable system of two connected disks. The steel cable, screwed onto the front disk, has to be connected to the pedal.

With the threaded hook you will now connect the cable from the knife to the treadle and adjust the knife at the proper height. Unscrew the threaded hook and barrel nut and reassemble them into the holes on top of the connection rail of the treadle.

Lead the cable one winding around the disk, hook the loop onto the hook, and guide the cable over the pulley, which is installed above on the bar in the middle section of the loom.

You can adjust the starting position of the knife to a lower or a higher level by screwing the threaded hook further down or respectively higher up. When you are doing this adjustment, you have to unhook the cable loop, otherwise the cable will undo the adjustment by twisting back while weaving.



The starting position of the knife has to be adjusted to a level so that the screw head of the farthest back shaft is just able to move freely under the knife.

## 8. Installing the cloth beam



Open hardware Bag 3, which is in Box C:

- 10 beam cords (if your Megado is a 70 or 110, you only need 6 or 8 of them)
- 1 ratchet wheel
- 4 screws 4 x 30 mm
- 1 ratchet
- 1 lag screw M6 x 30 mm
- 2 screws 4 x 13 mm
- 1 buffer and screw 4 x 21 mm
- 1 spring
- 1 screw eye
- 1 carriage bolt M8 x 75 mm with large washer, 33 mm bushing, small washer, and cap nut
- 1 threaded hook M6 x 60 mm with M6 barrel nut
- 1 brake cable
- 1 carriage bolt M8 x 50 mm with large washer, 5 mm bushing, small washer, and cap nut
- 1 hook with a Texsolv cord



Screw the ratchet onto the inside of the right side rail using the lag screw. Tighten the bolt completely and then reverse about half a turn so that the ratchet is able to turn freely.

Screw the two small 4 x 13 mm screws into the holes close to the ratchet. These screw heads keep the ratchet in position and limit its movement.

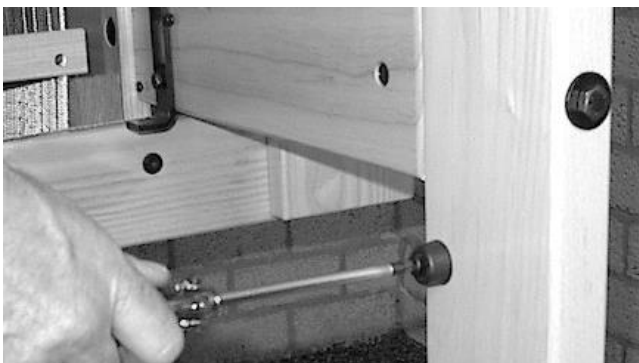

Screw the bumper with the 4 x 12 mm screw onto the inside of the front post on the right side.

Take the cloth beam out of Box C. Slide the ratchet wheel over the long shaft and install with the four 4 x 30 mm screws. Make sure the countersunk holes for the screws are facing out so that the screw heads fit.





Slide the cloth advance handle over the shaft against the ratchet wheel and install the cloth beam into the slots in the side rails of the loom.



Attach the beam cords to the screw heads of the cloth beam and the warp beam.

The Texsolv cords are cut at a joint between two loops. As a result, the end loop of a cord is not strong. Therefore attach the cords, using the second-to-the-end loop, over the screw heads of the cloth and warp beam.

### 9. The brake on the warp beam



Turn the screw eye into the right back post until only the eye protrudes. Use the screwdriver as a lever.



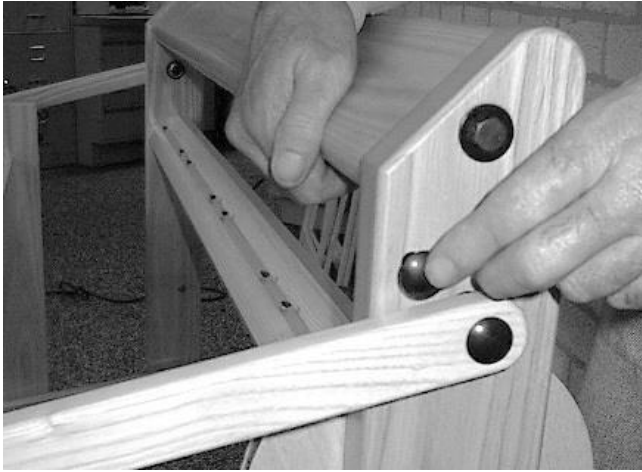

Insert the M8 x 50 mm carriage bolt through the back post after you have lifted up the back part of the loom (to prevent the hinged arm from interfering with the installation of the carriage bolt).

Slide the large washer, bushing, and small washer onto the bolt and tighten with the cap nut. Later on the brake cable will be installed onto this bolt.



Insert the M8 x 75 mm carriage bolt through the lower hole in the back post and slide the large washer and bushing onto it.

Tighten the cap nut and have the square part of the bolt head cut into the wood. Take the cap nut off again. This bolt is the shaft for the brake pedal.



Take the brake pedal out of Box B. Hook one end of the spring onto the eye of the pedal and the other end to the eye in the back post. Slide the hole in the brake pedal over the bushing onto the bolt.

Slide the small washer over the bolt and tighten with the cap nut.



The threaded hook for the brake cable has to be installed now on the short end of the brake pedal.

Insert the barrel nut into the hole and place the thread of the hook into the groove of the treadle. Now, screw the hook into the barrel nut until the threaded end protrudes about 3/4" (2 cm).



Place the brake cable with the largest loop around the bolt and wind the cable around the brake disk once, in the right direction (clockwise if you look from the camera side of the picture).

In this stage, the spring keeps the pedal end pressed against the shaft cords underneath the middle section. While pushing the pedal down in next step of the assembling, you have to take care that the pedal end does not interfere with the shaft cords!

Hook the cable loop onto the threaded hook while you use your other hand to push the pedal end down. Again, you could use some help to do this. If you are working alone, you can tie the pedal to the lower side rail so that you can use your two hands to install the cable.

Pull the brake pedal up so that the cable can set itself and check once more to see that the cable runs properly around the brake disk. Pushing the pedal down takes the tension off the cable, enabling you to make corrections if necessary.

#### Adjust the position of the brake pedal:

In the rest position, the brake pedal should be approximately horizontal. This can be adjusted by turning the threaded hook more or less deeply into the barrel nut. To do this, the cable has to be taken off the hook again. If you turn the eye bolt further into the barrel nut, the brake pedal comes down. If you turn the threaded hook further out of the barrel nut, the brake pedal will come up.



Hang this hook into the eye of the brake pedal with the cord around the neck of the eye.

Later on we will explain how this hook can be used to block the brake pedal in a position such that the brake is released.

## 10. Assembling the breast beam



Open hardware bag 4 from **box C**:

- 2 small screw eyes
- 1 nail
- 8 screws 4 x 17 mm
- 2 cords, 7 1/2" (19 cm) long
- 2 springs with screw eye and cord
- 2 carriage bolts M8 x 75 mm with large washer, 33 mm bushing, large washer, and cap nut.



Take the spring arms marked K and L out of box B.

Insert a carriage bolt through the hole in one of the spring arms so that the bolt sticks out on the marked side. Slide the large washer and bushing onto the bolt and insert the bolt through the hole in the top of the post marked K or L. Slide on the other washer and tighten with cap nut. Connect the other spring arm in the same way onto the other post.



Screw three screws into each of the spring arms. The heads have to protrude about 1/4" (5 mm).



Hook the Texsolv cord onto the middle screw of each spring arm.

Insert a screw through the second last hole on the other end of each cord and screw them into the holes of the backside of the front posts.

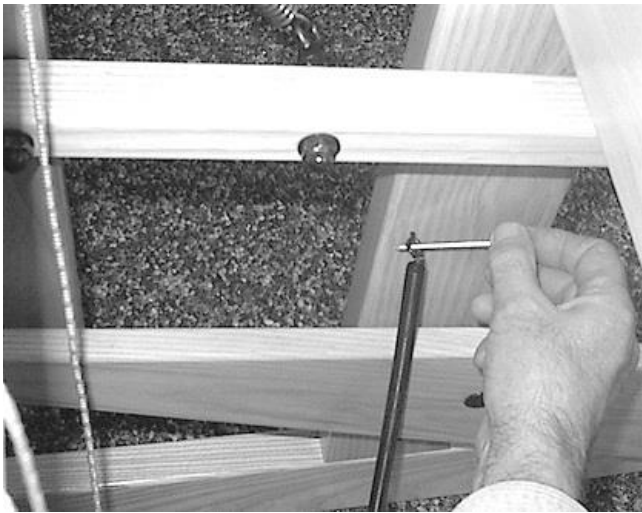

The eyes attached to the springs should be screwed into the holes on the inside of the middle posts. Use the nail to do this. Screw them so far that only the eyes protrude from the wood.

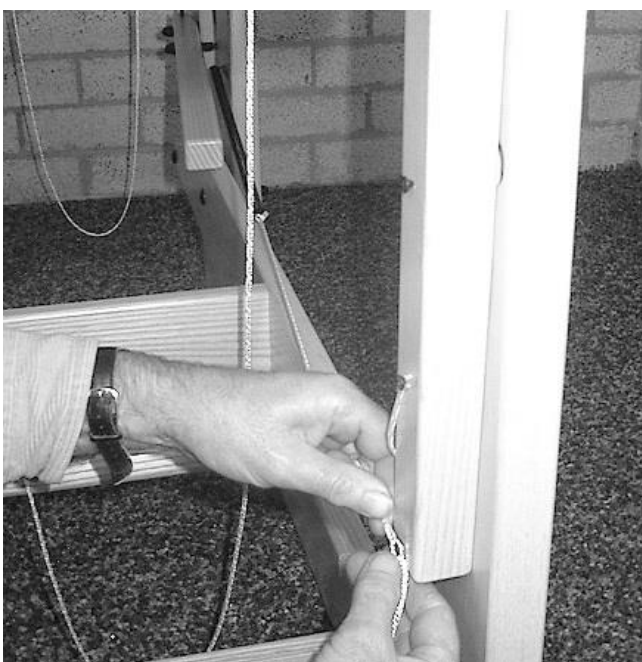

Hook the ends of the spring cords onto the bottom screw heads of the spring arms. When the loom is dressed you can set the warp tension using these springs, see also page 33: the moving breast beam.



Place the breast beam (from box C) onto the pins of the spring arms.



Use the nail, again, to screw the screw eyes into the holes on the rear of the back posts. These screw eyes can be used to tie up the cross sticks.

The lease sticks can be attached to these screw eyes. If you want to keep the lease sticks in your warp during weaving, they should never pass the back beam. They would shorten the effective depth of your loom for shed building.

Some weavers remove the lease sticks entirely while they are weaving. This is a matter of personal preference.

## 11. Assembling the beater



Open hardware Bag 5 from Box B:

- 2 hinges for the beater uprights
- 2 bolts M6 x 75 mm with washer and barrel nut
- 
- 2 carriage bolts M8 x 75 mm
- 2 large washers
- 2 star knobs
- 4 washers
- 2 bushings 33 mm
- 2 lag screws 90 mm
- 3 thin cardboard strips

Take the remaining parts out of Box B. These are the beater handle and the beater uprights. The top beater bar and the reed support have to be attached to the uprights.

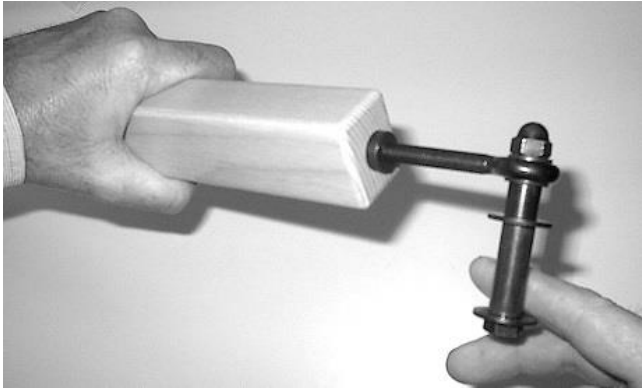

Screw the hinges into the bottom of the uprights. The exact height of the beater can be adjusted later on by screwing the hinges further in or out.

Attach the reed support (out of Box D) in the notches of the uprights, using the two M6 x 75 mm bolts, washers, and barrel nuts.



Place the entire assembly, uprights and reed support onto the loom. By keeping the assembly slightly tilted, you can guide one hinge around the side rail first and then the other.

Place the hinges into the grooves in the lower side rails.

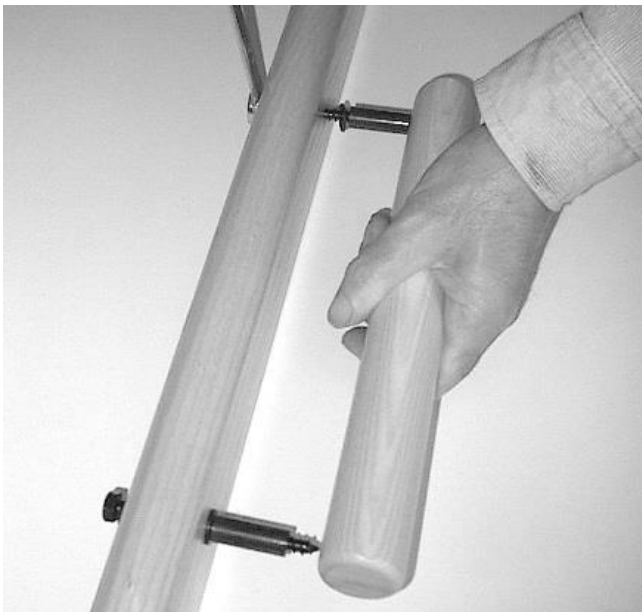

Slide a washer onto both lag screws and insert the lag screws into the holes in the top beater bar. If applicable, choose the nicest side facing the front (the side of the handle). Slide a washer and a steel bushing onto both lag screws. Turn the screws into the handle until the bushings fit tightly against the handle.

Insert the carriage bolts M6 x 80 mm at the front (the side of the handle) through the holes in the end of the beater bar and slide on the washers. Screw the wing nuts onto the bolts a couple of turns.





Insert the carriage bolts from the backside into the holes at the end of the upper beater bar, slip over the large washers at the front and screw the star knobs onto the bolts a few turns.

Assemble the top beater bar, placing the bolts into the grooves on top of the uprights.

The square parts of the carriage bolts, held by the groove of the uprights, prevent the bolts from turning, when you tighten the star knobs.

Tighten the star knobs, so that the top beater bar is high enough, allowing the reed to be inserted from the side. Slide the reed precisely into the center of the beater, loosen the star knobs and let the groove of the beater bar snap onto the top of the reed. Tighten up the star knobs again.

Now we will check if the beater is even and make a correction if necessary, using the thin cardboard strips that you found in hardware bag 5. First check if the hinges protrude the same distance from the bottom of the uprights.



Take the beater by its handle and pull it towards you some cm (1-2").

If the beater is even, both uprights will leave the buffers at the same moment and also touch the buffers at the same time when you let the beater go back and rest against them.

If this is not the case, the beater is not even and you will correct that with the small cardboard strips from the hardware bag.

The upright that leaves the buffer latest when you pull the beater, is the one that needs one or more cardboard strips in its slit connection with the lower reed holder. Unscrew the M6 bolt several turns, so that some play is created in this connection. Slide a cardboard strip completely into the slit at the bottom and fasten the M6 bolt again. Check for evenness again, adding strips in the slit as necessary.

## 12. Optional: Assembling the springs

When you put more weight on the back part of the loom by installing a sectional warp beam or a second warp beam, or with the wider looms it becomes a bit harder to lift the shafts. Therefore springs to help the lift are included with the wider looms (110 and 130 cm) and the mentioned accessories. These springs (hardware bag 6) can be installed if desired.

The wider your Megado is, the sooner you need the help of the springs. If the back part of the loom dances up after coming down, the springs give too much lift. The dobbie knife and the back part of the loom move together, so you can't change the dobbie for next shed as long as the back part is not resting down. It helps if you control the upward pedal movement by your

foot. By yes or no using the springs and adjust their effect, you will find the compromise between easy treading and weaving speed, that is convenient to you.

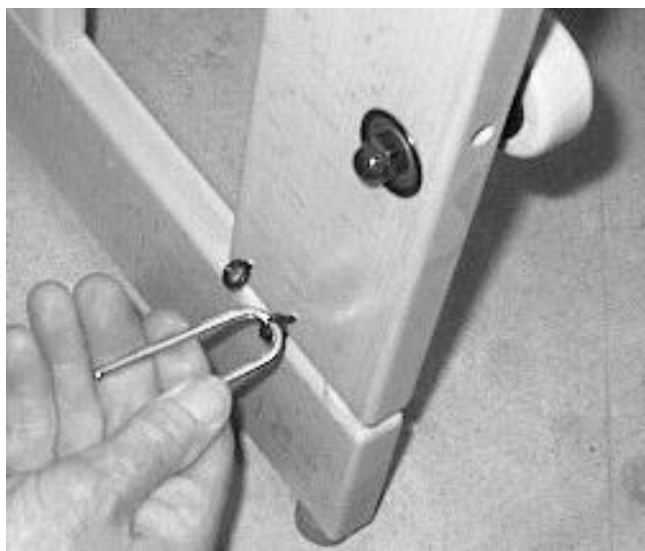

There are four pilot holes at the bottom of both back posts. Screw at each side of the loom the screw eye of a spring into one of these holes and connect the other end of the springs to a hook of the hinged arms. When you use the hooks and screw eyes more to the front of the loom, the springs will have more lifting power.

## Assembling the mechanical dobby system

This section only applies if the loom is provided with a mechanical dobby system.

The mechanical dobby head has a wooden roller driven by a treadle. A chain of program bars (also called dobby bars) runs along this roller. Each time you push the treadle, the roller makes a quarter turn to bring the next program bar into the proper position for selecting the shafts for the next shed.

The program bars have numbered holes that correspond with the shafts. The treading is programmed by inserting pegs into the holes of the program bars. These pegs push the dobby hooks into their active position.

### 1. Mounting the dobby head



Open the hardware bag, which contains:

- 2 threaded ends M6 x 134 mm with knurled nut, washer, and barrel nut
- 2 screw hooks
- 1 bolt M8 x 70 mm with two large washers, steel bushing and barrel nut
- 2 screws 5 x 50 mm
- 1 screw 4 x 35 mm
- 1 wrench 13 mm





Insert the barrel nuts into the holes in the sides of the middle section and screw the threaded ends into them.

Slide the dobbie head onto the threaded ends. Make sure the black plastic knob faces the front of the loom.

Slide the washers onto the threaded ends and screw the knurled nuts on tightly.

## 2. Assembling the dobbie treadle

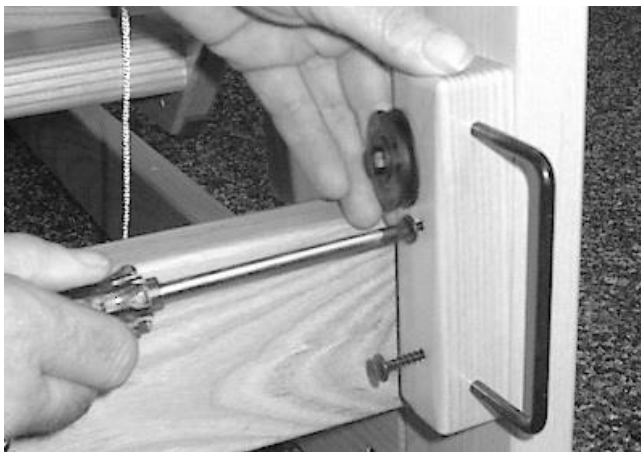

Screw the guide block for the dobbie treadle with the two 5 x 55 mm screws into the pilot holes on the inside of the right hand front post of the loom.

Insert the dobbie treadle from the right side through the brace of the previously installed guide block. Watch out for the proper position of the treadle with respect to the parts that have already been attached to the treadle, see following picture.

The M8 x 70 mm bolt is the hinge point for the treadle: Turn the barrel nut off and take only one washer from the bolt. Insert the bolt with one washer and bushing through the hole in the treadle and replace the first washer. Insert the barrel nut into the hole in the front post on the left side of the loom and attach the treadle by screwing the bolt into the barrel nut.



A support for your foot can be attached onto the foot rail.

### 3. Installing the blocking block



Use a book or two to make a stack at least 1" (2.5 cm) high and slide them underneath the right side rail while you lift the loom on that side. A threaded M8 end with two large washers, a small washer, and a cap nut have been assembled in the blocking block.

Take off the nut and one of the washers from the threaded end. Insert the threaded end with the blocking block into the hole at the bottom right hand side rail.



Replace washer and nut onto the threaded rod that now protrudes under the side rail. Tighten nut and cap nut securely using two 13 mm wrenches and then remove the book(s).

A spring and a cord are attached to the screw eye in the blocking block. The cord has to be attached to the dobbie treadle. The spring has to be attached to the middle post and will, by pulling the cord through, bring the dobbie treadle in its highest position.

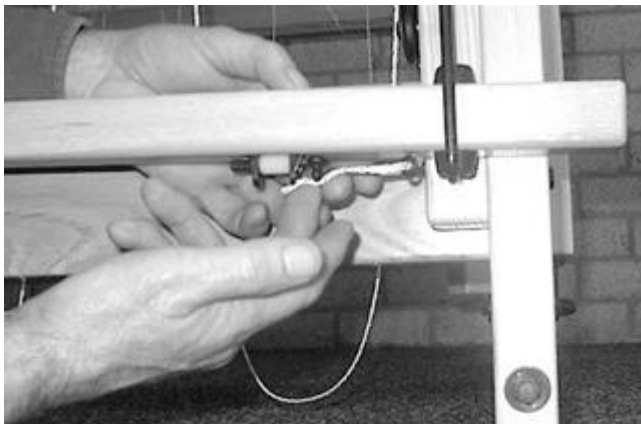

Guide the cord through the eyelet on the bottom of the treadle and attach onto the plastic hook.



Take one of the screw hooks and screw it into the pilot hole on the middle post. Loop the eye of the spring around the hook. Guide the cord over the pulley above the treadle. When you push the dobbie treadle down, the blocking block turns under the treadle for the shed and consequently prevents this treadle from moving. When you push in the treadle for the shed, the blocking block cannot be turned, so it prevents the dobbie treadle from moving.

Adjust the position of the blocking block by turning the knurled nut at the bottom of the dobbie treadle and/or altering the cord loops on the plastic hook. By shortening the cord, you will reduce the space between the blocking block and the depressed shed treadle. This space should be about 3/8" (1 cm).

#### 4. Installing the bar with the rollers for the cords



You have to attach this bar with the guide rollers, using the hole that you will find on the right side of the shaft section of the loom in the lower cross bar that is farthest back.

Take the bar with the three rollers and remove the M8 carriage bolt (with one roller, three washers, and a cap nut). Push the carriage bolt from the inside through the hole on the cross bar and slide the bar with the rollers onto it, so that the two rollers point sloping downward, see picture.

Next slide two washers, the roller, and the other washer, which you have previously removed, onto the protruding bolt. Tighten with the cap nut until you can just move the bar around the bolt to adjust its position later on.

#### 5. Assembling the reversing disk

With the reversing disk (see pictures on next pages) you can reverse the movement direction of the program bar chain. The treadle drive of the dobbie mechanism runs via this disk. The disk has to be attached to the outside of the right front post. The carriage bolt, washers, bushing, and cap nut, which you will find in the center hole of the disk, are required for this assembly.

Remove the bolt from the disk and insert it from the inside, through the hole on the front post. Now slide the big washer, the bushing, the disk, and the cap nut onto the carriage bolt and tighten the nut securely. Make sure that the square neck of the bolt is fully pulled into the wood.

Take the remaining screw hook out of the hardware bag and screw it into the pilot hole of the front post, just under the cap nut of the spring lever. You have to attach the spring of the reversing disk to this hook later on.

#### 6. Assembling the anchor and the cords connecting the anchor to the reversing disk

On the back of the dobbie mechanism you will find a wooden knob with four nylon rollers on the inside. The knob is held in position by a spring wire, pressing against two of these rollers. When you turn the knob, you push the spring wire out first before it flexes back in and presses against two rollers again. This cycle takes a quarter turn of the wooden knob (90 degrees). The square wooden bar, which is connected to the knob, advances the program bars into position.

Every time you push the dobbie treadle, the knob is turned 90 degrees by means of the anchor; which is the angular piece of steel wire. Cords attached to both ends of the anchor will be guided over the rollers and connected to the reversing disk.



Remove the plastic hooks from the cord ends. Slide these ends through the back into the holes of the reversing disk. Replace the plastic hooks and press them into the black holders on the disk, the tips of the hooks pointing towards the bottom of the groove.

Turn the disk in position so that the longest cord comes from the upper hole. Guide the cords around the back of the beater upright and over the two pulleys of the angled pulley bar. The longest cord from the top of the disk should run over the top pulley.



Guide the cords over the other pulleys, as seen on the picture. The anchor will then be properly placed up against the rollers behind the knob.

Slide the pulley bar so that the cords beside the bar run parallel and screw the remaining screw into the hole of the pulley bar and fasten the bar in its proper position. Now tighten up the cap nut of the pulley bar completely.

## 7. Adjusting the tension of the cords

The reversing disk is held in position by the two cords that connect the disk to the anchor. If these cords are taut, the free play of the disk corresponds with the play of the anchor. In rest, the two cords will always have the same tension. If you tighten one of them, the position of the disk will alter a little and the increased tension will be divided over both cords.

You can adjust the cord tension by turning the knurled nylon nuts, or inserting the hooks into the next cord loop.

To get an impression of the needed tension, just touch the shaft cords, by way of example, at the bottom of the shaft section of the loom. The tension on the cords to the anchor may be a bit more.

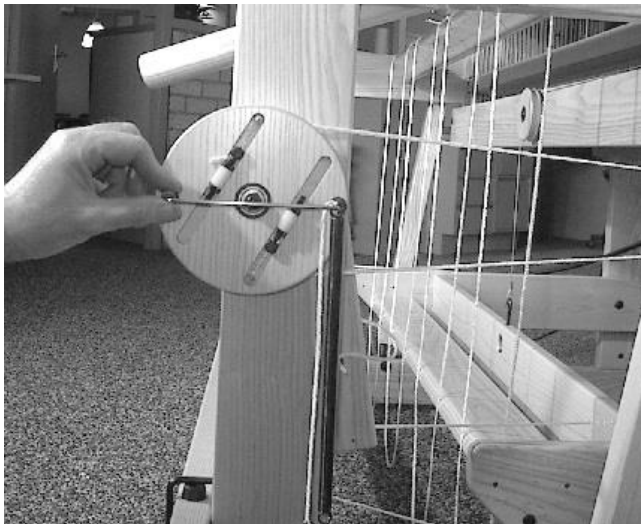

Adjust the cords so they are taut and so that the metal guide on the reversing disk is horizontal.

There is some play in the position of this guide, but it is important that the average position is horizontal. Check as follows:

You pick up the guide on the left side and while you move it up and down, you look for the free play. If the free play above the horizontal position on the left is greater than below, you have to tighten the bottom cord of the reversing disk.

Conversely, you have to tighten the upper cord if the left side of the guide has greater free play below the horizontal position.

Of course, tightening one cord has the same effect on the disk position as loosening the other cord. If the cords have the proper tension, you can adjust the position of the disk by screwing one of the knurled nuts towards the tip of the hook and unscrewing the other the same number of turns.

## 8. Attaching the treadle to the reversing disk

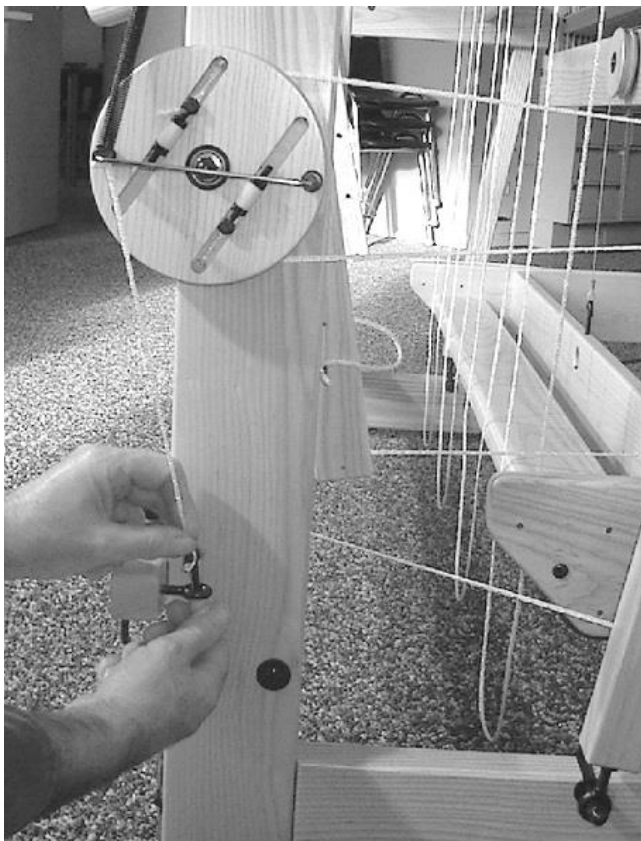

Attach the spring onto the hook at the top of the front post and slide the other end of the spring to one side of the guide. On that side the spring will pull up the guide a bit, due to the play in the disk.

Attach the cord of the spring to the eye of the treadle by means of the hook and the knurled nut. The washer should be placed in between the eye and the nut. Tighten the knurled nut until the guide is pulled exactly in a horizontal position.

Now if you slide the spring to the other side, the guide will be kept in a horizontal position too.

If you have carried out the last steps of these instructions correctly, the dobby mechanism will make a quarter turn when you push in the treadle, and it will reverse direction when you slide the spring to the other side of the guide.

You can evaluate whether the adjustment has been done accurately by turning the black plastic knob on front of the dobbie mechanism.

In both positions of the spring, you must be able to turn the knob both ways with equal ease. If this is not the case, recheck the adjustments.

### 9. Installing the program bars

Disconnect the chain of program bars by pushing the grey connecting pegs on each side towards the inside and then pull them out of the chain.



Guide the program bars over the two wooden pulleys, so that you can see the numbers while you deposit the first bar into the groove at the top of the wooden roller.

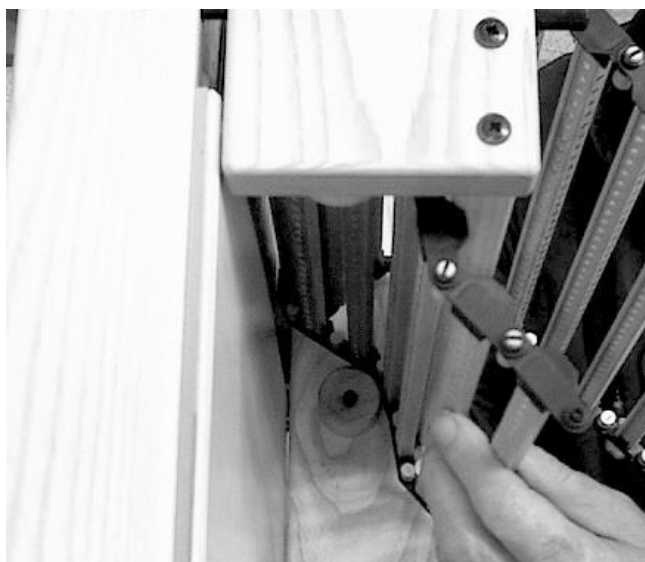

Turn the roller with the knob two positions, take the first bar from underneath the roller, and guide the program bars towards you, while turning the roller further. The chain of program bars must pass over the round wooden supports (see picture).



Reconnect the ends of the chain of bars with the grey pegs. Connecting the links of the chain requires some skill, because the right and the left sides have to be done at the same time.



You can place stickers on the side chain joints in order to number the program bars. While you are weaving, you can see which program bar is active by looking through the opening between the dobby head and the side of the loom.

The program bars turn around when they turn over the wooden roller, so the sticker numbers in the picture are upside down.

## Installing the electronic interface

Please refer to the manual provided with the electronic interface for details on installing the electronic interface.

## Tips and tricks for using the loom

### Points of attention

Do not remove the ties from the bundles of heddles before the shafts bars or something else has been put into the heddle openings. The ties are required to keep the heddles properly organized.

With some weave structures there are many warp threads on the first two shafts. To help these two first shafts moving down when the shed closes, we have added some additional weight to them.

Do not leave the lease sticks in the warp between the back beam and the shafts while you are weaving. The effective depth of the loom is reduced if they are there, and the warp is therefore subjected to an excessive amount of tension when the shed is formed. If you are used to leaving lease sticks in the warp, attach them to the two eyelets at the back of the loom. They will then stay between the back beam and the warp beam when you advance the warp.

To help the shafts slide properly along each other during weaving, it is necessary to have some heddles at both ends of all shafts, especially when you weave a small project.

For the mechanical dobby: Do not change the dobby position while you push the treadle that creates the shed. The treadle for the dobby system and the treadle for the shed are interlocked. Only one can be operated at a time, the other is then locked. However, you can change the dobby by hand when the shed treadle is pushed down. Should this accidentally happen, or if the dobby knife becomes stuck between the screw heads for some other reason, you can easily undo this situation: Turn the knob for manual operation 45 degrees and push down the shed treadle and then let the treadle go up again.

The front shafts move less and are subjected to less force than the back shafts. If you do not use all the shafts, use the ones closest to the front.



It is very important that the steel guides at the ends of the shafts are properly placed into the shaft bars and that the cords are securely placed in the grooves of the shaft bars.

### Installing the heddles to the shafts



Texsolv heddles consist of a double polyester cord that is connected at specific distances. This chain of heddles is folded in a zigzag fashion into bundles of one hundred.

With a sharp pair of scissors, cut the loops between the heddles.

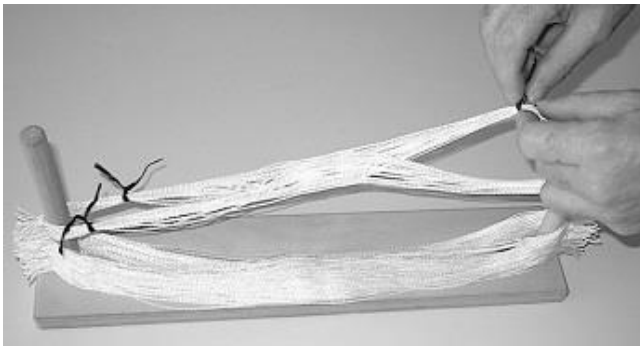

Count the desired number of heddles for each shaft and make bundles by tying the heddles in four places. Always place more heddles than you actually need on each shaft.



The sides of the shafts are made of spring steel and have a right-angled bend at the ends. The bended end fits in a hole in the groove at the ends of the shaft bar. The shaft can be "opened" by taking this spring steel end out of the shaft bar.

With your thumb, push on the end of the shaft bar while you pull the shaft side out with your other fingers. Pull the shaft side close to the shaft bar and give, as shown in the picture, some back pressure with your little finger so that the end of the steel wire does not get stuck in the hole.



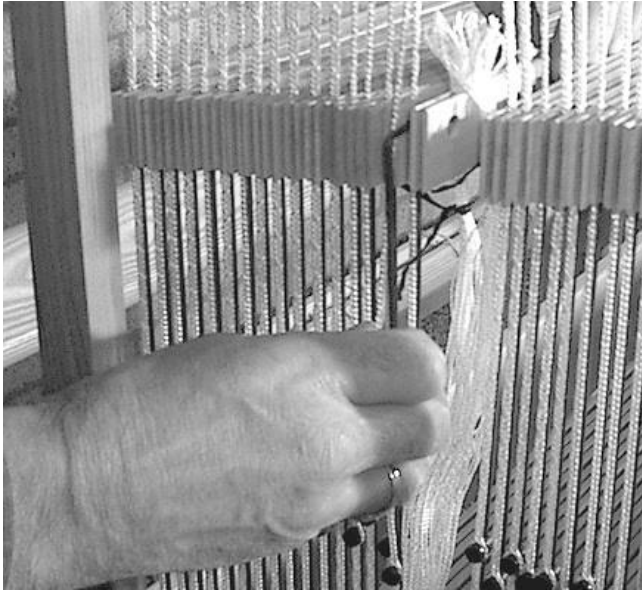

Slide the bundle of heddles onto the shaft bar, replace the shaft side into the groove, reinsert the bent end into its hole, and replace the cord into the groove.

Remove the two ties that hold the top part of the heddles.



To install the heddles onto the lower shaft bar, we recommend placing the shaft in a higher position:

If the chain of program bars is installed onto the dobby head, then turn the roller until you come to a bar without pegs, so that no dobby hooks are active, or turn the roller 45 degrees into an in between position.

Push the dobby hook forward for the shaft you want to add heddles to and then push down the treadle to raise the shaft.

Position a book, a box or another object between the lifted upper shaft bar and the remaining ones to keep the shaft up when you release the treadle.

Now open the shaft at the bottom and slide the heddles onto the shaft bar.

Remove the bottom two ties off the heddles. Close the shaft again by putting the shaft side back into the shaft bar and let the shaft bar go down by removing the object that supported it.

Removing heddles should be done in the reverse sequence. Remember to tie them first. If you are used to threading the warp from left to right, make sure you have a sufficient number of heddles on each shaft. If you run short of heddles, it is much more difficult to add heddles on the right side of the loom than on the left.

### **Blocking the brake pedal during the beaming-up of the warp**

When you are beaming the warp, the brake pedal should be depressed or blocked in the down position using the hook that hangs on the eye of the brake pedal.



While pushing the brake pedal down, you can attach the hook to the bolt of the hinge point located on the treadle where it is connected to the back part of the loom.

By changing the length of the Texsolv cord, you can adjust the friction of the brake. Adjust the friction to the point where you can easily turn the crank on the warp beam, but where the beam does not turn back by itself when you let go of the crank.



You can adjust the length of the cord by using the next cord loop and you can shorten the cord more precisely by spinning the hook to give the cord a twist.

After unlocking the brake again, replace the hook on the eye of the pedal, otherwise it can damage the wood while the back part of the loom moves up and down.

### **Blocking the back part during the beaming-up of the warp**



In order to prevent the back part of the loom from being pulled up during the beaming of the warp, you need to block the back part in its lowest position.

If your Megado has a mechanical dobbie, you can achieve this by taking the spring off that connects the blocking block to the frame of the loom.

If your loom does not have a mechanical dobbie, you can block the treadle and the back part by putting some books under the treadle.

### **The apron rods and the tying-on of the warp to the cloth beam**

The apron rod of the cloth beam is a bit shorter than the apron rod of the warp beam, because when you wind the cloth on the cloth beam, the rod has to pass between the spring arms. Make sure that the apron rod does not get caught behind a spring arm.

The apron rods are marked where the beam cords must be tied. For each rod, make loops in the cords and put the rod through them. Position the loops on the pre-marked spots. Pull on the rod to check whether the cords are equally tight. If required, correct them by loosening the loops and then tightening them again by pulling on the rod.

When you are ready to tie on the warp to the apron rod, remove the cloth protector on the breast beam by unscrewing the plastic knurled bolts at both sides.

After weaving has begun and the apron rod has passed the breast beam, you can put the cloth protector back in place.

When you tie the warp onto the apron rod, you will need to block the moving breast beam, otherwise it will be impossible to get equal tension on all the warp threads. Take the spring cords off the spring arms so that the breast beam becomes blocked by the cords that are connected from the spring arms to the front posts of the loom.

### **The moving breast beam**

You use the moving breast beam to set the warp tension. As long as you do not change the settings, you can weave the whole project with the same tension. The warp tension can be adjusted by shortening or lengthening the spring cords or by using the lower or top screw head on the spring arms to which you can attach the cords. Fastened to the top screw heads, the springs exert less tension on the breast beam. You will reach the highest warp tension when you stretch out the springs and attach them with a small piece of cord to the lower screw heads.

### **Adjusting the height of the beater**

The hinges in the bottom of the uprights of the beater are threaded. You can turn these hinges in or out (on both sides of the loom), allowing you to adjust the height of the beater very precisely.

The height of the beater should be adjusted so that the warp threads rest in the bottom of the reed on the shuttle race. This allows the shuttle race to properly support the shuttle. The reed and lower reed support should not push the warp threads up. This would result in the heddle eyes resting on the warp so that the shafts that have to be kept down during a shed, would not be locked in the lower position.

### **Advancing the warp**

Lightly push the brake pedal of the warp beam. Due to its spring supports, the breast beam will pull a bit of warp from the warp beam and move it forward.

Now turn the cloth beam, and when the spring arms of the breast beam are back in the same position as before you released the brake, you will have the same amount of tension in the warp. The first beatings after advancing the cloth always influence the warp tension a little so you may have to adjust by turning the cloth beam one more notch of the ratchet wheel.

If you have turned the cloth beam too tightly (the spring arms pull the springs too far), you can release tension by pushing in the brake pedal just a bit.

If you advanced the cloth too far, you can reverse it as follows:

- Release warp tension by pushing the brake pedal.
- Take both ratchets out of the ratchet wheel of the cloth beam and turn the beam backwards.
- Return the ratchets into the ratchet wheel again.
- While pushing the brake pedal down, wind the necessary amount of warp back onto the warp beam until the spring arms reach the vertical position in which they produce the warp tension that you have previously chosen for your weaving project. If the needed tension is too high for adjustment by beaming, you can adjust it by advancing the cloth.
- If you beamed back too far, release the brake and advance the cloth to its proper position.

## Maintenance

The Megado requires no special maintenance. However we do advise checking the tightness of all bolts, nuts, and screws after a couple of months. This is particularly important when the loom is standing in a dry environment. Repeat this once a year.

## Trouble shooting

If the knife makes a noise while moving, a drop of sewing machine oil on the ends that run in the grooves will solve the problem.

### **A shaft is slanted**

Possible cause: The clamp that fixes the shaft side to the cord has become loose.

The screws in the clamps have a Phillips head, so the screwdriver that is supplied with the loom will not fit properly, but most cross head screw drivers are Phillips head and will fit. Let all shafts rest in their lowest position and fix the clamp to the shaft side by tightening the screw.

If it should occur that a shaft is loose at both sides, you have to take care that the dobbie hook for that shaft is in line with the other dobbie hooks during the time you are fixing the shaft sides to the cords.

### **A shaft that should stay down, comes up when you make a shed**

Possible cause: The dobbie hook of the faulty shaft did not come high enough after the previous shed. The screw head should snap back above the blocking plate. Because the screw head stays against the blocking plate, the dobbie hook remains extended forward and will be picked up by the knife, making next shed.

One reason why this happens is that the shaft does not go down to its lowest position because it sticks to a shaft bar of the neighboring shaft. Leave some heddles at the ends of all the shafts. This will help to guide the shafts along each other. Also be sure that the Texsolv cords run through the slots of the shaft bars. Another reason for the problem that a screw head does not come high enough to block its non-selected shaft could be the level adjustment of the shaft in its cords, i.e., the shaft comes back to its lowest position, but at this position the screw head does not slide over the blocking plate snapping into the locking position. To check this you need to take the dobbie mechanism or interface off the loom first. When the shafts are in their lowest position, there must be a 2-3 mm (1/16" - 3/32") clearance between the screw heads and the blocking plate.

If it is necessary to adjust this distance with a shaft, follow this procedure:

To prevent working on the wrong shaft, mark the shaft that needs adjustment with a piece of colored yarn on both ends. Loosen the small bolts of the clamps that hold the shafts on both sides to the cords just enough so that the clamps can be moved on the shaft ends. (Please note that the heads of these bolts require a Phillips screwdriver, not supplied with the loom.) When the bolts are loose, you can adjust the shaft in relationship to the cords, and by doing so, to the dobbie hook. Tighten the bolts again while the shaft is in its lowest position and the head of the blocking screw is 2-3 mm (1/16"-3/32") above the blocking plate.

### **One shaft sticks 10 mm (about 1/2") above the other shafts while it is in its lowest position**

Probable cause: You loosened one of the shaft bars on both sides, and by accident, fastened it upside down.

## **The shed is too small**

### Possible causes:

- The knife of the dobbie system is adjusted too high. Refer to point 7, page 11 for instructions.
- The beater is adjusted too high.
- The warp has to be advanced.
- The cable of the pedal doesn't run properly around the disk that drives the knife.

## **One of the treadles cannot be pushed down**

Possible cause: Your foot is resting on the other treadle and you have inadvertently blocked the treadle that you want to operate.

## **The dobbie treadle cannot be pushed in**

Possible reason: The spring for the reversing disk sits half way on the guide instead of in the forward or reverse position.

## **When you push the shed treadle, there is no shed**

### Possible causes:

- The cable of the treadle has become undone.
- To prevent overheating of the interface, it becomes inactive if you wait a while before making next shed. Activate the interface again with your software.
- There are no pegs in the program bar that you just put into position.

## **While weaving, the tension in the warp changes**

### Possible causes:

- The brake cable is not mounted properly on the disk. The windings are to be positioned neatly, next to each other.
- The brake pedal is adjusted too high and is released by touching the middle section when the back portion hinges up.

During the assembly of the loom the brake pedal was adjusted horizontally. After using it for some time, you will find that the brake pedal has come up a little. Check the cap nut of the carriage bolt, the hinge point of the pedal, and make sure that the nut is tight.

### Adjust the brake pedal a little lower, back to a horizontal position:

Stand beside the loom and push the pedal down. Slip over the brake disk side one winding of the cable, so that the tension is released. Now let the pedal go and have both hands free for adjustment. Take the cable loop from the threaded hook and twist the hook clockwise for several rotations. Hook on the loop again and push down the pedal so that you can replace the cable onto the disk. Check again the height of the pedal.

## **The warp does not come loose from the warp beam when the warp is advanced**

### Possible causes:

- The brake pedal has to be pushed in further.
- The warp tension you use for your project is too low to pull the warp from the warp beam.

This can happen if you make a small cloth from fragile material. In this case you will need to advance the warp beam a little by hand, while you push the brake pedal. If you weave with a low warp tension, the lease sticks, if left in the warp, could give too much restriction to allow the warp to be moved forward. Remove the lease sticks from the warp.

- The brake cable crosses itself on the brake drum.

The cable makes two turns around the brake drum. The cable must lie on top of the drum and not cross over itself, which causes the cable to hold on and not release when the brake pedal is pushed in. To release the cable again, it is necessary to remove the tension from the cloth beam by disengaging the two springs that hold the moving breast beam and taking both ratchets out of the ratchet wheel. Now you can turn the warp beam back a bit and the cable will come loose so you can position the brake cable properly. Do not forget to put the springs for the moving breast beam back in place again.

### **The cloth cannot be wound onto the cloth beam**

#### Possible causes:

- One of the ratchets is not locked into the ratchet wheel.
- The apron rod of the cloth beam hits one of the spring arms.

### **The roller of the mechanical dobbie does not come into the next position completely when you push down the treadle**

#### Possible causes:

- You do not push in the dobbie treadle far enough.
- The cord between the treadle and the reversing disk is too loose or too tight.
- The position of the reversing disk is not properly adjusted.
- The cords connecting the reversing disk to the anchor are not properly positioned over the rollers.

### **With the mechanical dobbie, the knife is stuck between the screw heads of the dobbie hooks**

#### Possible causes:

- You moved the dobbie by hand while you kept the treadle for the shed pushed in.
- With a second warp beam and a sectional warp beam we supply extra springs, which help to compensate for the extra weight of the back part. If these springs are adjusted with too much tension, you will experience that the whole back part of the loom bounces when the shed treadle is released. If the dobbie position is changed at the moment that the back part jumps back up, screw heads above the knife can come forward and block the knife.

In both cases you can eliminate the problem by turning the roller of the dobbie head half way between two positions and moving the knife up and down with the treadle for the shed. All the screw heads will come free. When the knife is all the way up again, you turn the roller into a fixed position.

## Contact

If you still have a problem after reading this instruction, please contact your dealer or Louët directly.

Louët BV  
Kwinkweerd 139  
7241 CW Lochem  
The Netherlands

Phone: + 31 (0)573-252229  
Fax: + 31 (0)573-253858

E-mail: [info@louet.nl](mailto:info@louet.nl)  
Website: [www.louet.nl](http://www.louet.nl)